



# MINESWEEPERS

TOWARDS A LANDMINE-FREE WORLD

[WWW.LANDMINEFREE.ORG](http://WWW.LANDMINEFREE.ORG)



# Landmine Detection Sensors

## Contents

- Metal Detection
- Ground Penetrating Radar.
- Electromagnetic Induction Sensor.
- The Infrared Sensor (IR).
- The Ultra Sound Sensor.



## Metal Detectors

(MDs) are a mature technology and are the primary means of detection used in mine detection.

### One Coil Principle

- When a metal target enters the field, eddy currents circulate within the target.
- This causes a load on the sensor, decreasing the amplitude of the electromagnetic field.
- As the target approaches the sensor, the eddy currents increase, increasing the load on the oscillator and further decreasing the amplitude of the field.
- The trigger circuit monitors the oscillator's amplitude and at a predetermined level switches the output state of the sensor from its normal condition (ON or OFF).
- As the target moves away from the sensor, the oscillator's amplitude increases.
- At a predetermined level the trigger switches the output state of the sensor back to its normal condition (ON or OFF).

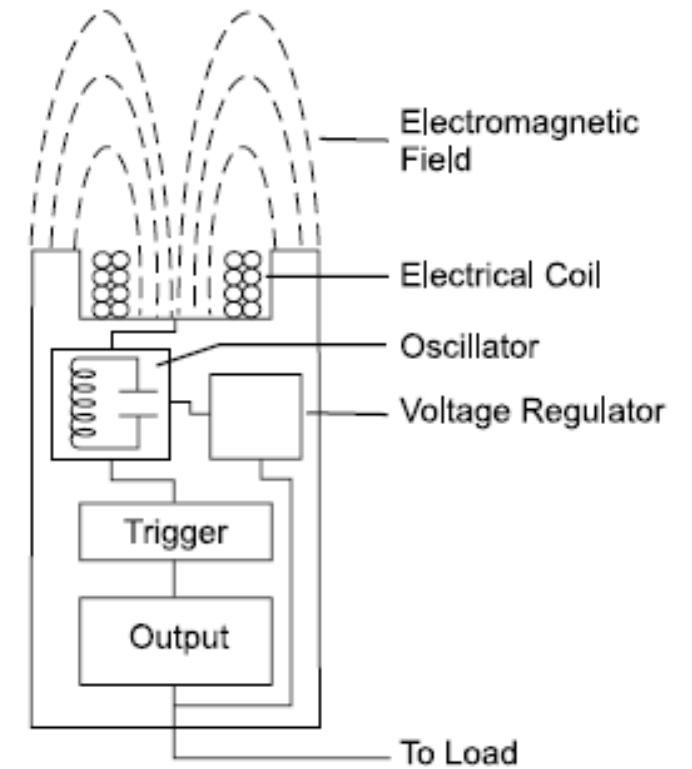

## Two coil Principle

### Operating Principle

- A metal detector's search head is usually composed of a primary coil (transmitter) and one or more secondary coils (receiver), although in some arrangements one coil is actually sufficient.
- A time-varying current in the transmitter coil generates a low frequency electromagnetic field (kHz to MHz frequency range), which induces electric ("eddy") currents in nearby metallic objects.
- These eddy currents in turn induce a time-varying current in the receiver coil(s), which is amplified and processed to provide an acoustic signal or other form of warning or signal strength indication as the detector is swept over the ground. typically very close to the soil.



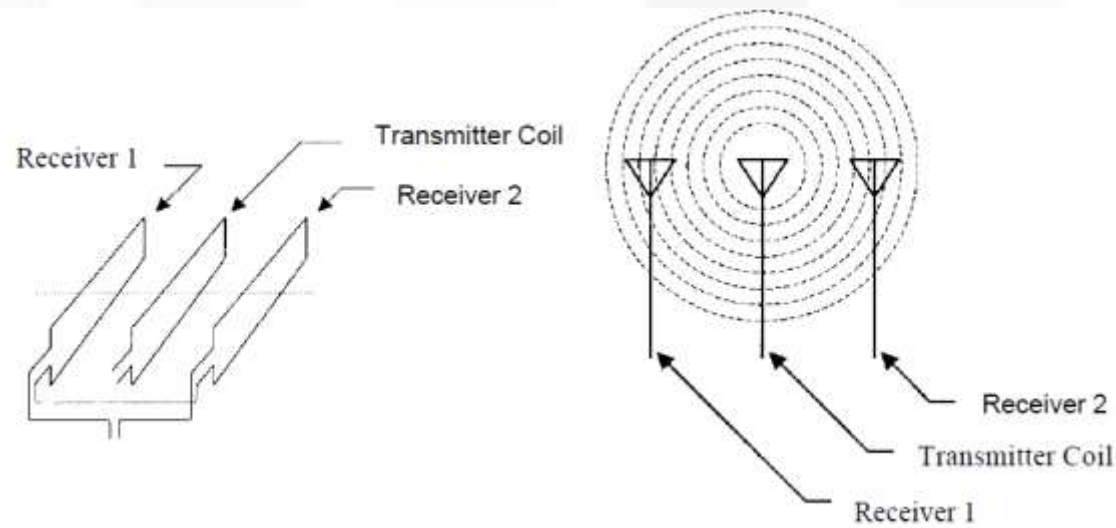

- The figure shows equally spaced on either side of the transmitter coil two receiver coils
- The field is generally trapped inside the shielded enclosure of the detector but some field escapes from the aperture on both sides of the detector. Anything that enters into this field that is either **Magnetic**, or Electrically **Conductive** will cause a disturbance in the field strength around it.
- All metals have either one or both of these characteristics and will be detectable if the size of the signal is large enough.
- The signals from the receiving coils are connected in opposition to each other and therefore when no disturbance is occurring there will be a net signal across the coils of zero — they are balanced.
- As metal passes through the detector the balance will be offset as the contaminant enters the aperture and again as it leaves the exit side. This disturbance is amplified and analyzed by the control electronics and detection will occur if the sensitivity threshold has been exceeded.





## Strengths

- Well-established technology (hand-held; vehicle-based arrays are more recent developments).
- The vast majority of all deployed mines do contain some amount of metal, albeit.
- Indicative detection limits (can also depend on ground conditions): shallow (about 10-15cm for minimum-metal mines, 20-30cm for mines with an appreciable metallic content, and 50-70cm for UXO and metallic mines). Greater depths are reachable with large loop systems.



## Limitations

- Magnetic (e.g. laterite rich) or strongly conductive soils (e.g. sea beaches).
- Ground compensation techniques can reduce detector sensitivity.
- Very small (minimum-metal mines) and/or deep targets, low conductivity metals (e.g. stainless steel).
- Footprint size decreases with depth (conical footprint).
- Electromagnetic interference (e.g. power lines). High false alarm rate caused by metal fragments, etc.

## Potential for Humanitarian Demining

- Well-established technology.
- Metal detectors (MDs) are present in nearly every multi-sensor system being researched.
- Efficiency limited by metallic debris (MDs detect any metal and not just the metal components found in mines).
- Recent improvements in soil signal suppression (fielded systems).
- Appealing but challenging innovations: target identification and parameter estimation (e.g. target depth/size), imaging applications, and sensors other than coils.
- Complemented in humanitarian demining, when a real need exists (UXO only, or deeply buried UXO), by magnetometers, which measure the distortion of the Earth's magnetic field caused by nearby ferromagnetic objects



## Ground Penetrating Radar

### Introduction

- Ground penetrating radar (commonly called GPR) is a high resolution electromagnetic technique that is designed primarily to investigate the shallow subsurface of the earth.
- GPR can provide precise information concerning the nature of buried objects.
- GPR uses the principle of scattering of electromagnetic waves to locate buried objects.

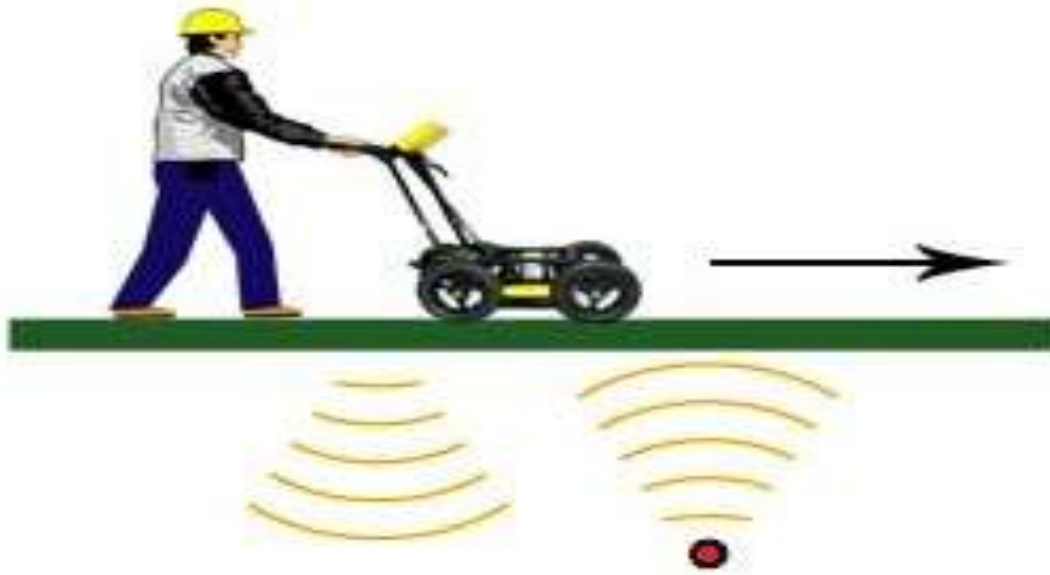

The controller measures the time taken for a pulse to travel to and from the target which indicates its depth and location.





- GPR is an electromagnetic (EM) geophysical method which is non-destructive  
EM energy is transmitting into the ground and a receiver measures energy that is reflected back to the surface from a buried body or interface .
- GPR is very useful for locating buried object – pipes, ducts, water mains, gas lines etc. and defining sub-surface structures.
- GPR technique is based on the measurement of the travel time and the reflection amplitude of a short electromagnetic pulse transmitted through a medium.
- GPR can provide continuous and nondestructive measurement compared to some traditional highway detection methods, and is widely applied in thickness measurement, crack detection and pavement moisture-content measurement.



# GPR Block Diagram

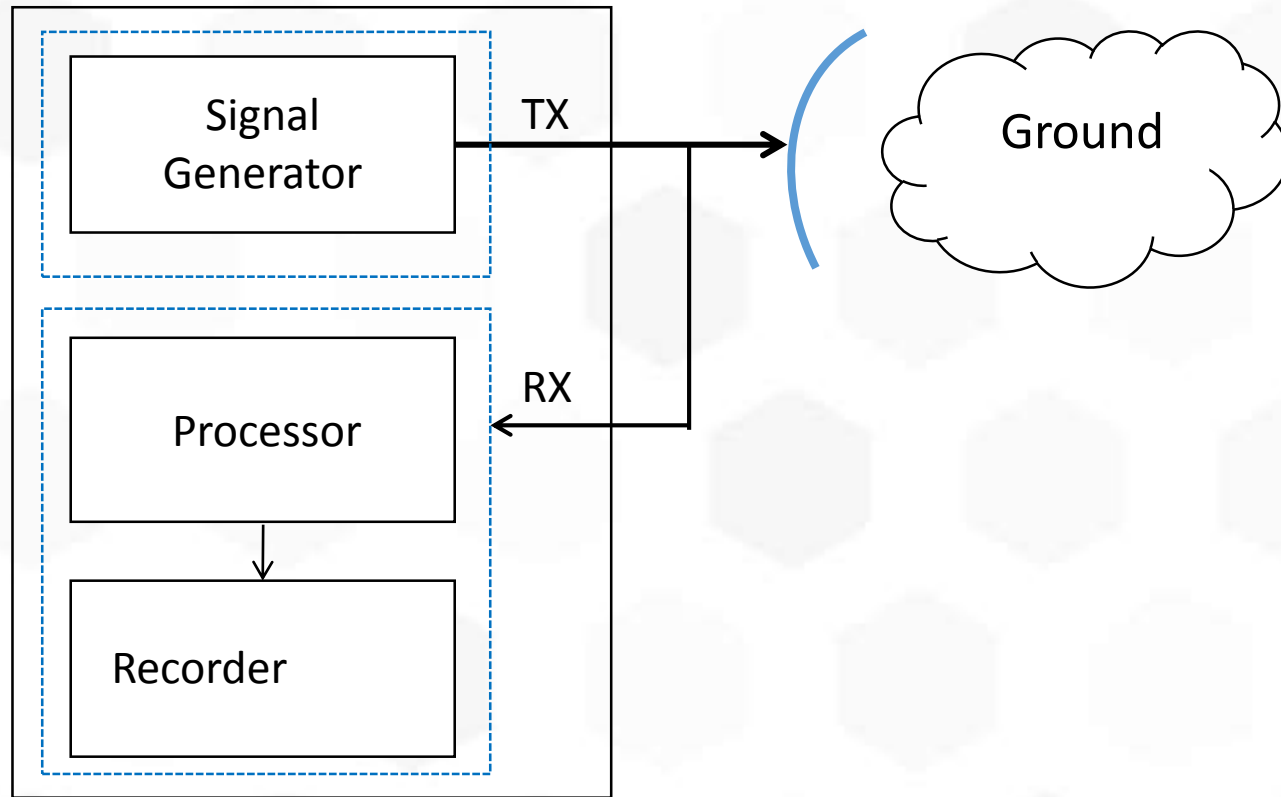

## GPR Operational Requirements

- Efficient coupling.
- Adequate penetration of the EM waves with respect to target depth.
- Obtaining a sufficiently scattered signal.
- An adequate bandwidth in the recovered signal with regard to the desired resolution.



The GPR system is mainly composed of six parts:

1. Transmitter.
2. Transmitting antenna.
3. Receiver.
4. Receiving antenna,.
5. Control/circuit unit (including controlling, sampling, filtering and amplifying functions).
6. Laptop computer with data acquisition card, used to control the GPR system and process the sampled data.



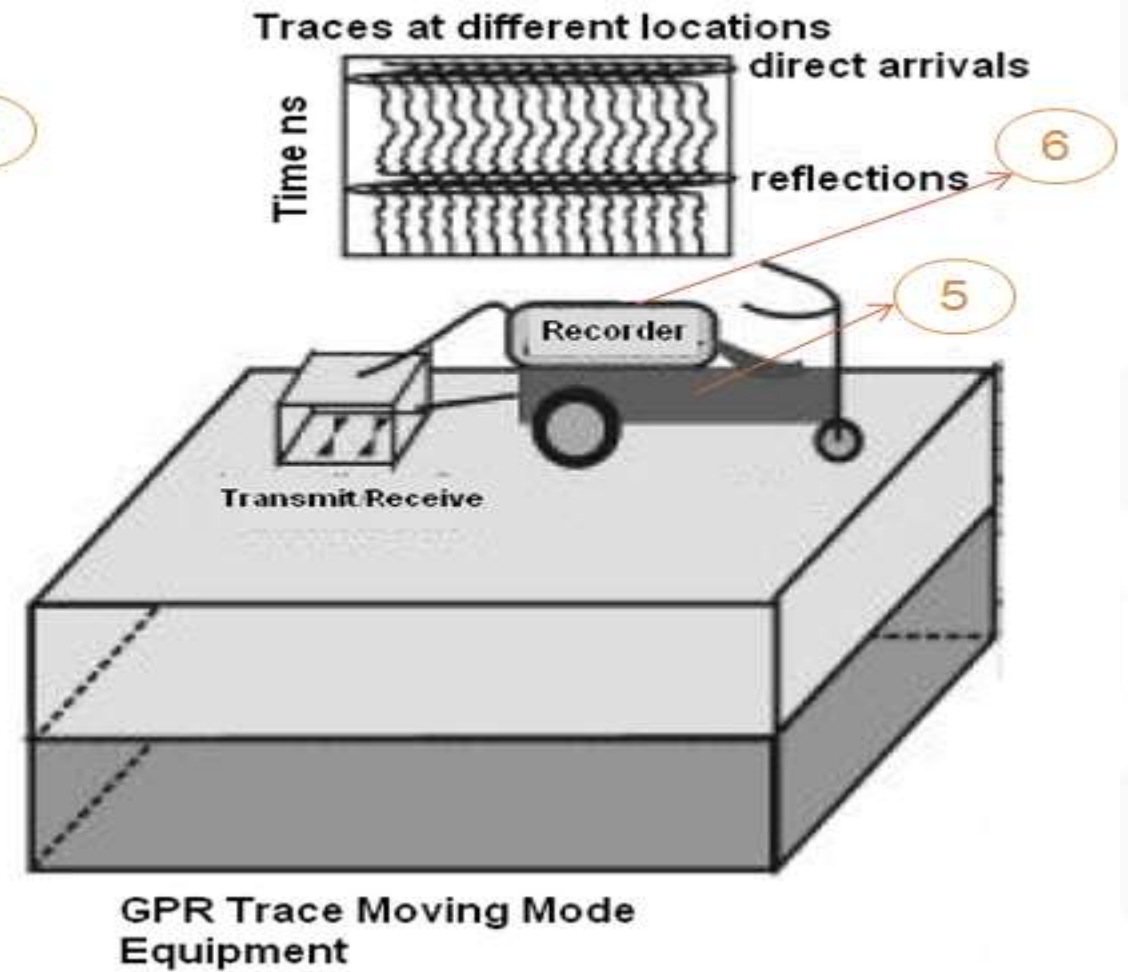
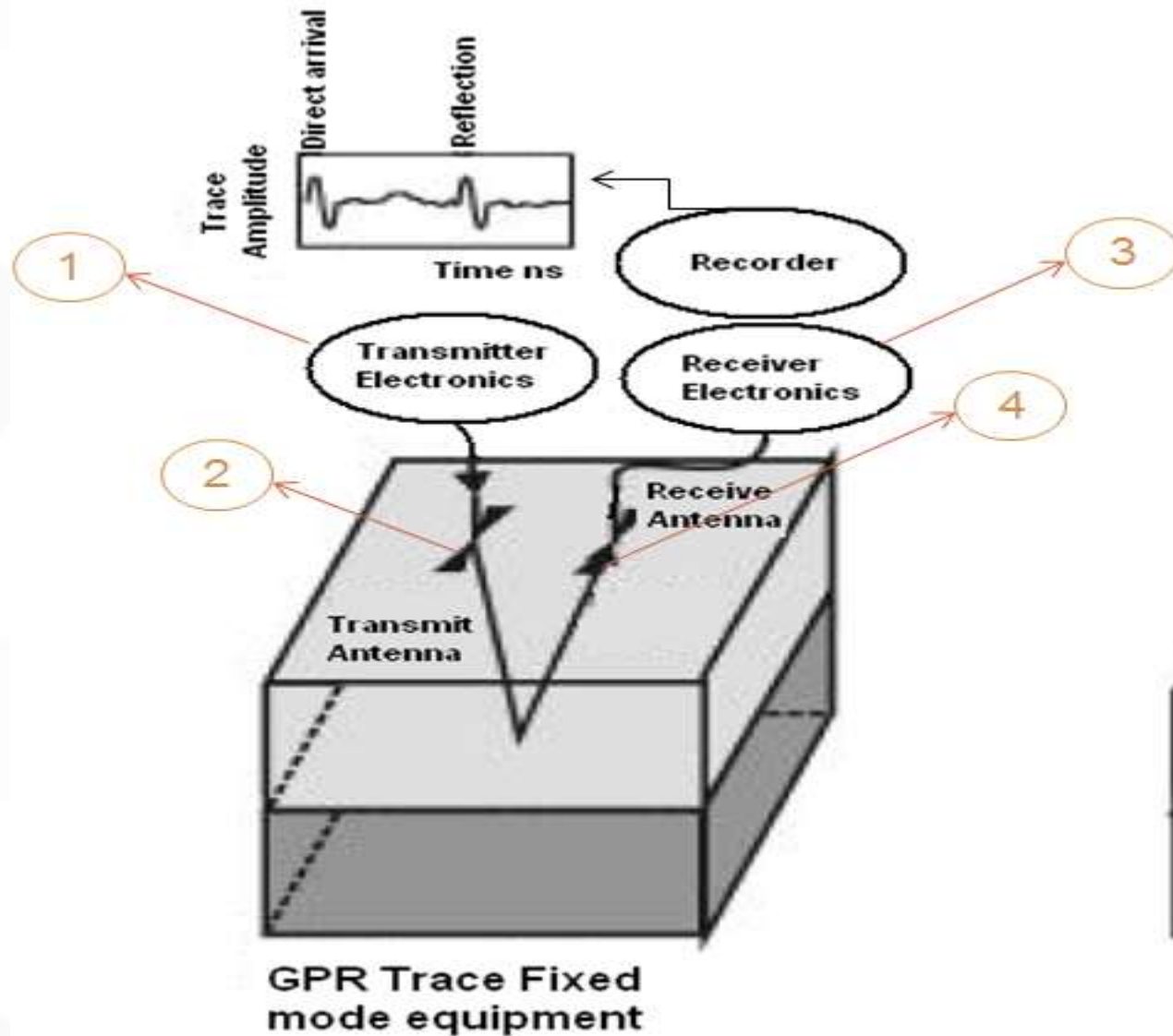

GPR equipment consists of antennas, electronics and a recording device, The transmitter and receiver electronics are always separate

## GPR Theory of Operation

- Works on the principal of reflection and refraction theory of electromagnetic waves.
- Uses radio waves to create picture of underground.
- Profiles is used to locate any variations in the sub-surfaces.
- Electrode magnetic waves emitted into the ground and time measured for wave to be reflected and received.
- Mainly governed by the electrical properties of the ground i.e., the dielectric constant of the media, which is nothing but measure of the ability of the material, which allows the electromagnetic energy to propagate through it.
- When wave hits areas of change in soil, it is hit back to receiver antenna.
- Changes in soil can include changing of electrical properties of different layers underneath the surface .



$$R = \frac{v}{2} \Delta t$$

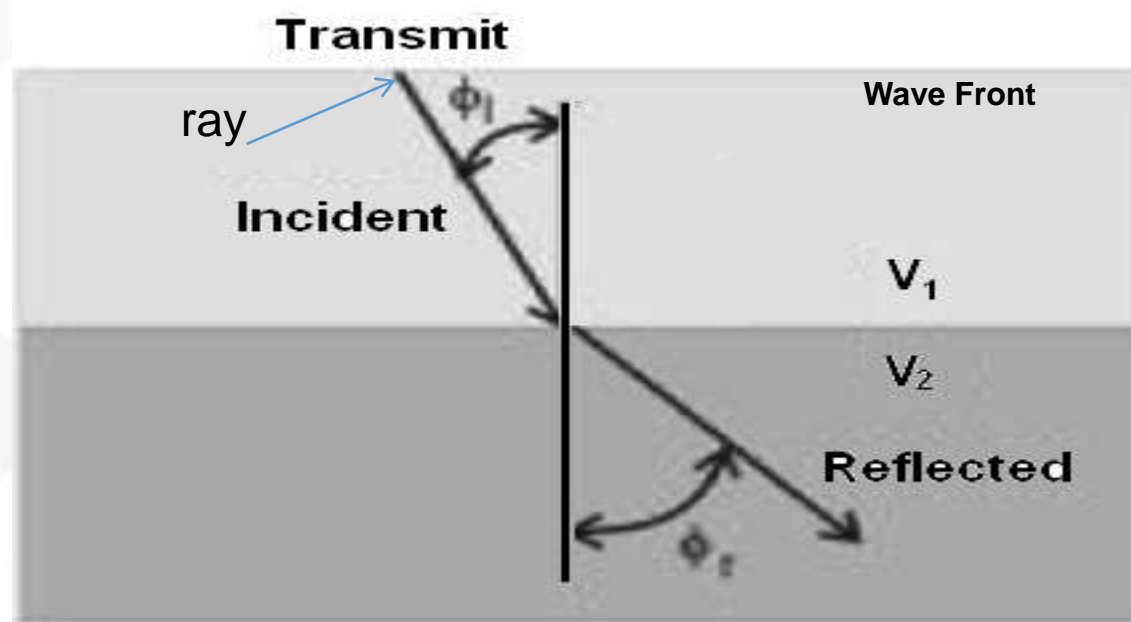

- The electromagnetic wave is radiated from a transmitting antenna, travels through the material at a velocity which is determined primarily by the permittivity of the material.
- The wave spreads out and travels downward until it hits an object that has different electrical properties from the surrounding medium, is scattered from the object, and is detected by a receiving antenna. The surface surrounding the advancing wave is called a wave front.
- A straight line drawn from the transmitter to the edge of the wave front is called a *ray*.
- Rays are used to show the direction of travel of the wave front in any direction away from the transmitting antenna.
- If the wave hits a buried object, then part of the waves energy is “reflected” back to the surface, while part of its energy continues to travel downward.
- The wave that is reflected back to the surface is captured by a receive antenna, and recorded on a digital storage device.



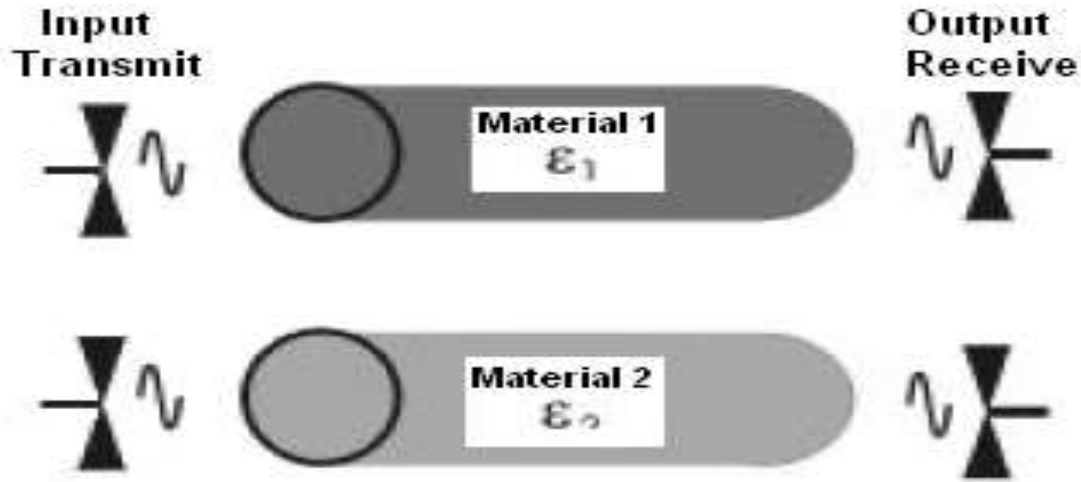

Samples with different permittivities and input/output pulse

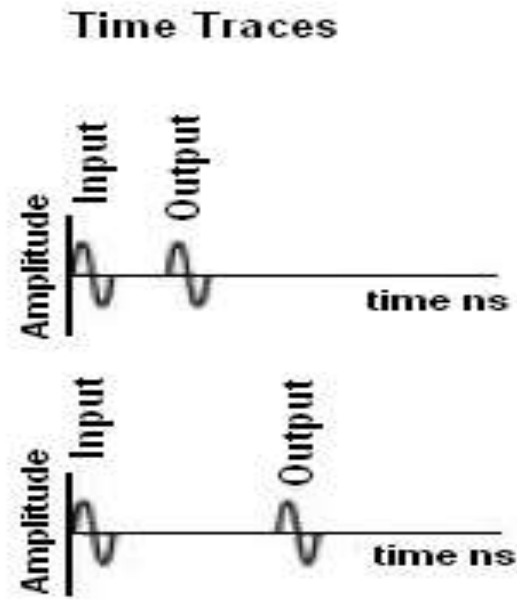

input and output signals plotted as a function of time

- If a at precisely the instant that the pulse is transmitted, then two pulses will be recorded by the receive antenna.
- The first signal will be the wave that travels directly through the air (since the velocity of air is greater than any other material), and the second signal that is recorded will be the signal that travels through the material and is scattered back to the surface, traveling at a velocity that is determined by the permittivity ( $\epsilon$ ) of the material.



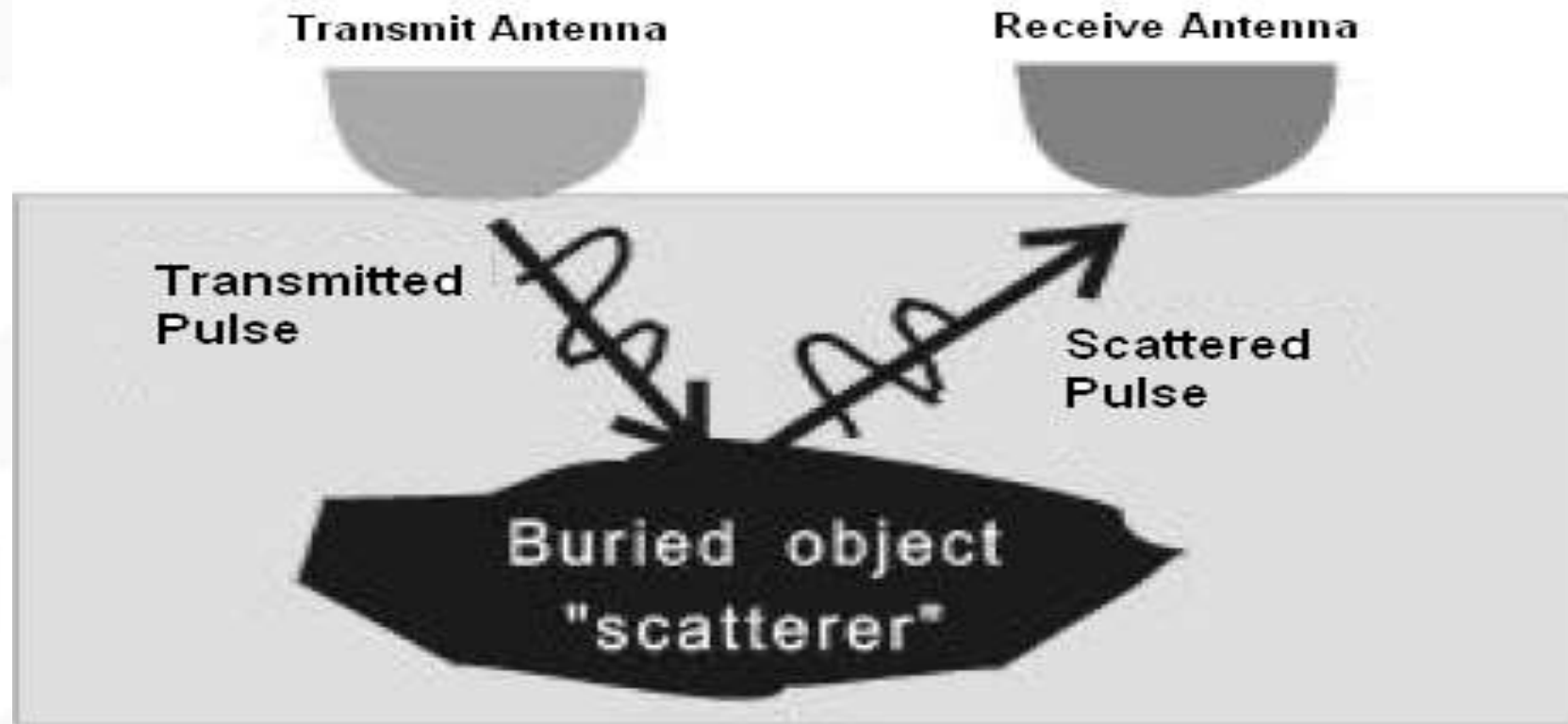

Relative amplitude of the trace

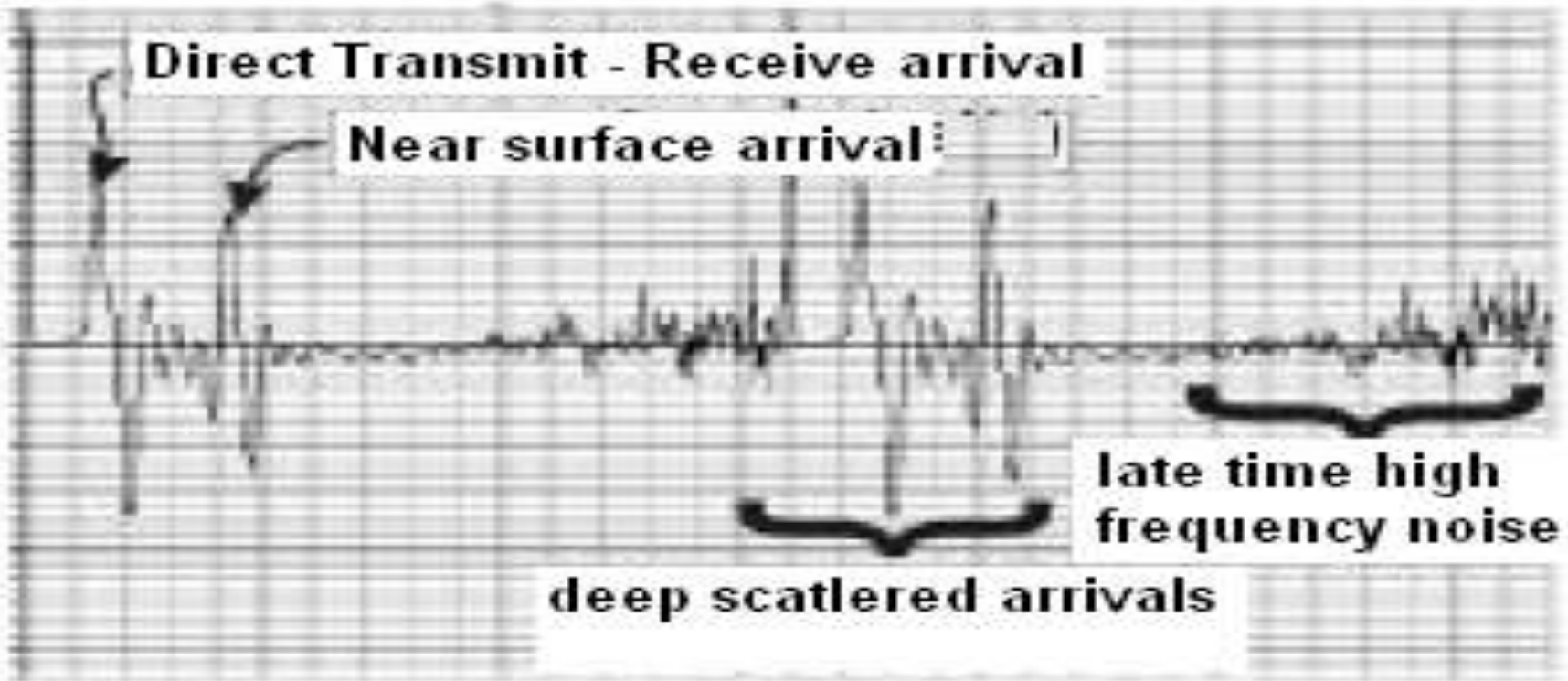

Travel Time, in Ns

the received energy is recorded as a trace at a point on the surface



## GPR Advantages

- 1- GPR provides a three dimensional pseudo-image that can easily be converted to depths that are accurate down to a few centimeters.
- 2- GPR responds to both metallic and non-metallic objects. GPR is an excellent tool for mapping nearly any inhomogeneity in the subsurface that is characterized by a small difference in density, or porosity.



## EMI Sensor

### Introduction

- Electromagnetic Induction Sensors work by sending out magnetic fields and detecting the response from the electric currents generated when the field interacts with a metallic target.
- Simple versions of these sensors are capable of detecting most land mines.
- Advanced sensors are required to tell the difference between a land mine and harmless buried metal objects, which can include bottle tops, nails, shrapnel and spent bullets.
- If the target is composed of ferromagnetic material, it can easily be detected by EMI (Electro Magnetic Induction) sensor, if it is in the detection range.



## Theory of Operation

- The method is based on Electromagnetic Induction (EMI) technique, where two different coils are used, transmitter coil creates primary magnetic field and receiver coil takes induced magnetic field.
- If there is a ferro-magnetic object in the region, receiver coil field is induced by small eddy currents originated by metallic objects, additionally.
- These additional currents are converted to voltage, utilizing appropriate circuits to produce warning signals.

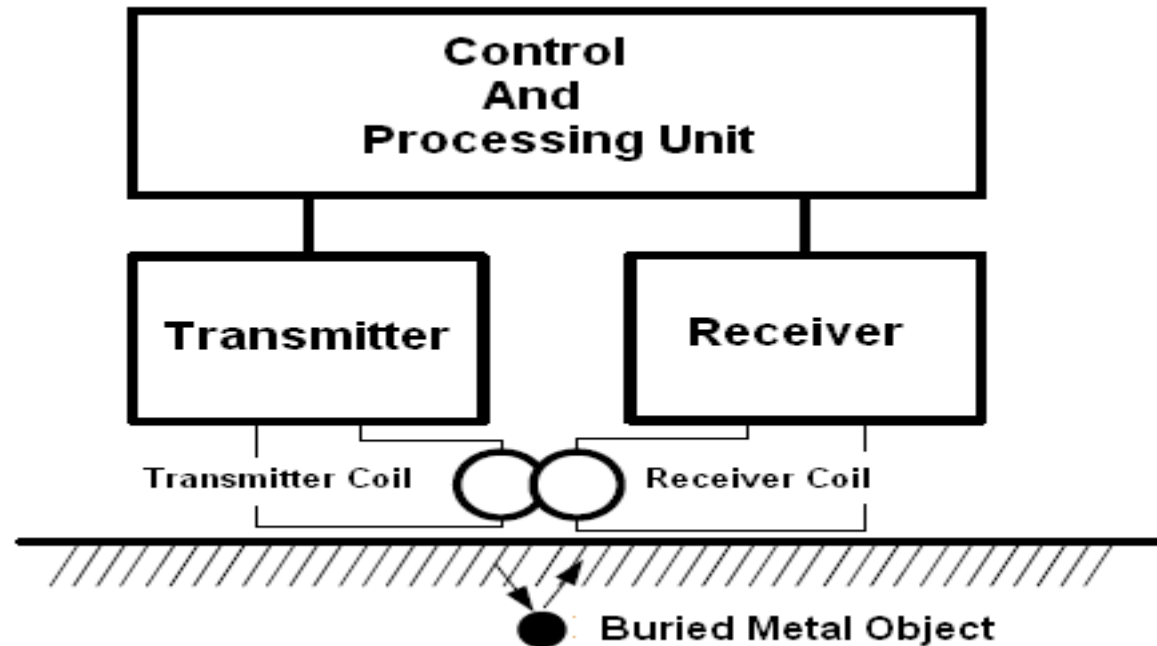

# Conductivity Sensor

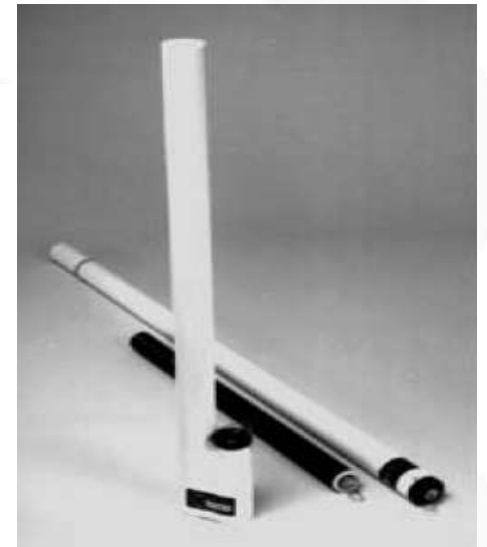
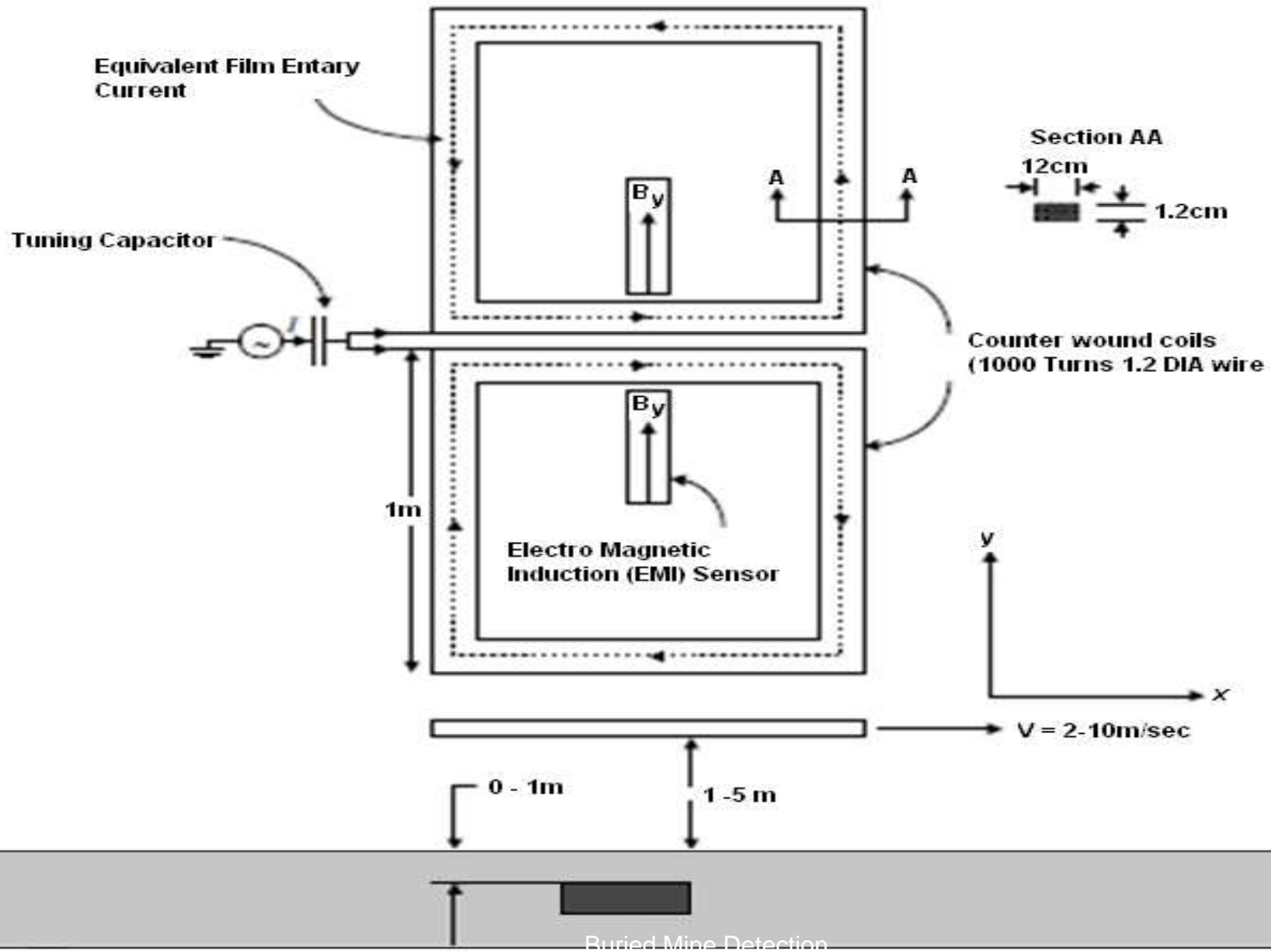

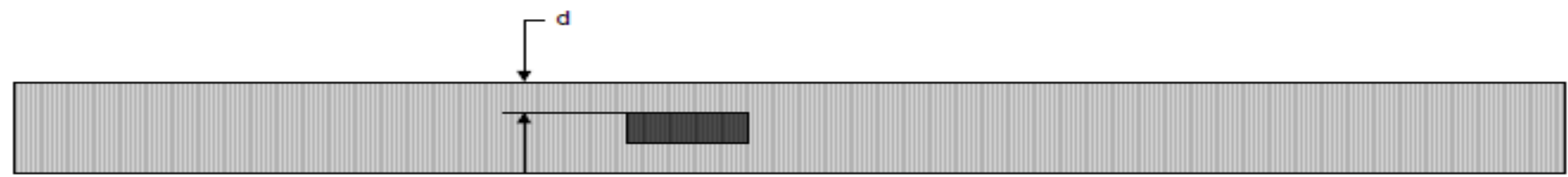
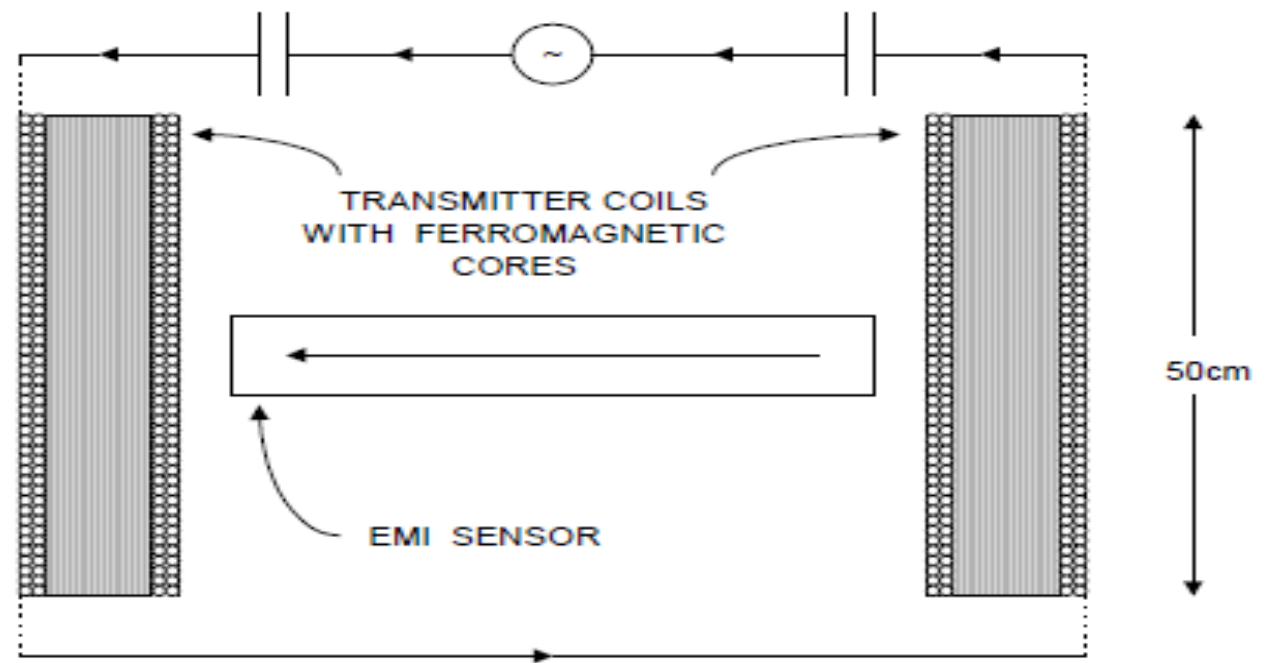
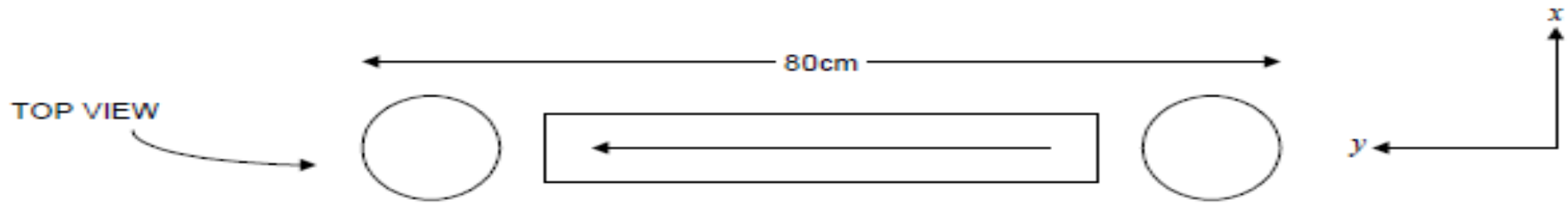

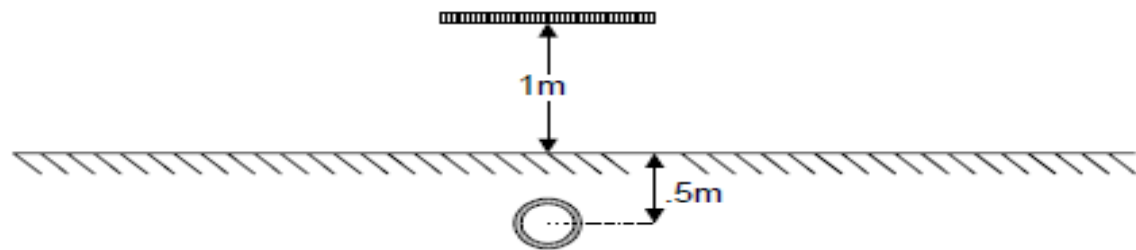
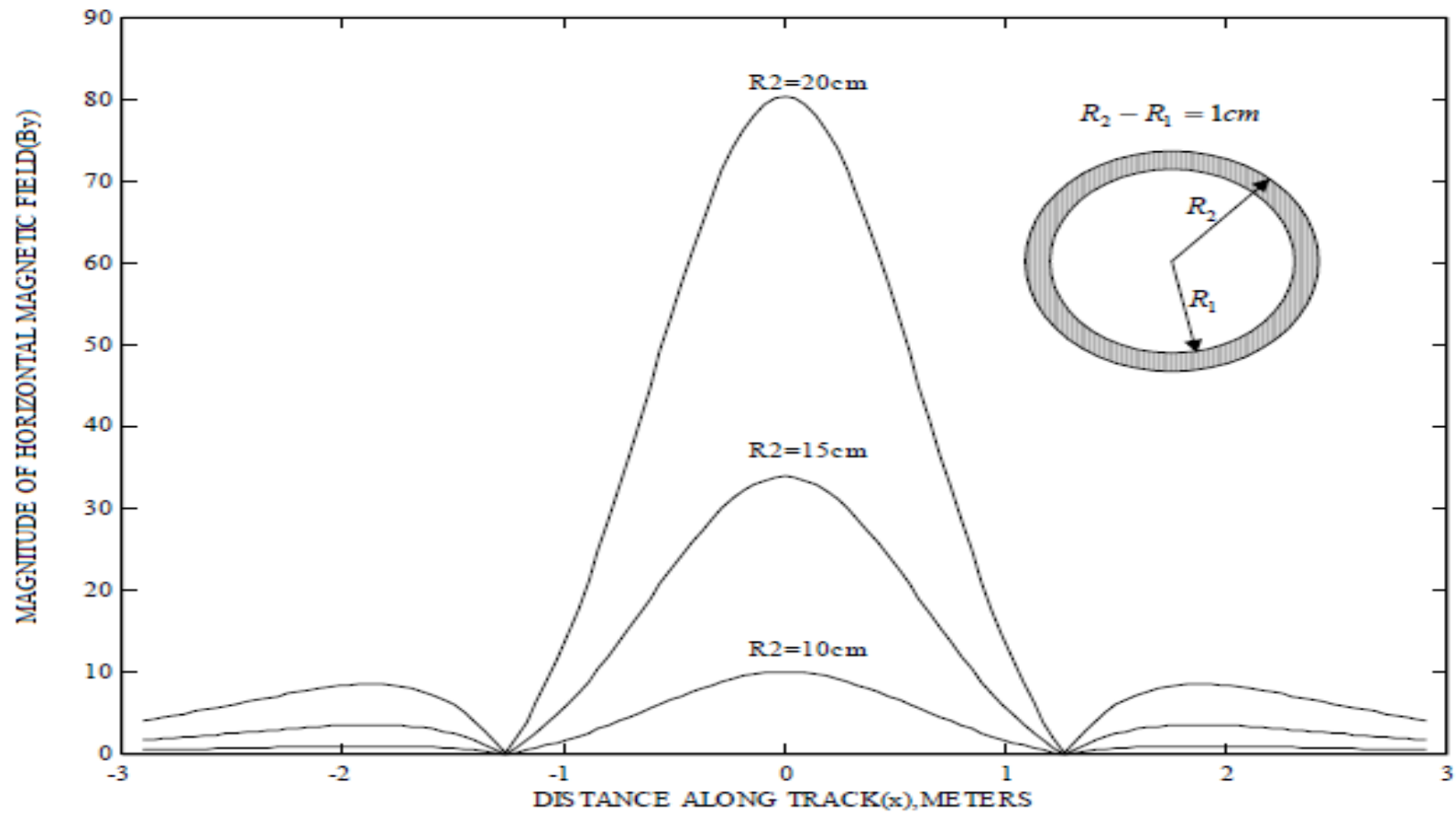



## Features

- Detection of plastic covered mines in dry soil
- Localization within 1 sq.m
- Retain the capability to detect metallic and non-metallic mines
- Deep penetration capability (several meters)
- Classification -metallic and non-metallic
- Shallow mines can be detected from a height of several meters

## Transmitter

- Two horizontal multi-turn coils resonant at the transmitter frequency
- Nominal transmitter power 200 w.
- Operating voltage 220 at (30 - 50 KHz).

## Receiver

- Detects temporal changes in amplitude and phase of the induced magnetic field as the electric field of the moving transmitter sweeps across the spatial subsurface conductivity in homogeneities
- A coils EMI sensor detects the fluctuations of the horizontal magnetic field or its gradient.
- A synchronous detector provides i & q channel outputs followed by filters and a threshold device



# The Infrared Sensor (IR)

## Introduction

Between microwaves and visible light are infrared waves. Infrared waves are sometimes classified as "near" infrared and "far" infrared. Near infrared waves are the waves that are closer to visible light in wavelength. These are the infrared waves that are used in your TV remote to change channels. Far infrared waves are further away from visible light in wavelength. Far infrared waves are thermal and give off heat. Anything that gives off heat radiates infrared waves. This includes the human body.

## Infrared

- IR radiation is a portion of the EM spectrum lying between the visible rays and microwaves regions with wavelengths between  $0.75\mu\text{m}$  and  $1\text{mm}$ .
- Although all EM radiation produces heat, IR radiation can be more readily detected for the heat.
- Heated materials provide good sources of infrared radiation. Therefore, IR radiation is referred to as thermal radiation.
- Since visualization is easier than other sensors, IR has been widely used for mine detection.



- ❖ Mines retain and release heat at different rates than their surroundings.
- ❖ By taking thermal IR images and analyzing thermal contrasts to locate mines.
- ❖ This technique is used mainly to detect antitank mines on roads where environmental conditions are minimized.
- ❖ IR is mainly useful for detecting hotspots in the morning before sending a robot out.
- ❖ IR radiation can be more readily detected for the heat. Heated materials provide good sources of infrared radiation.
- ❖ IR radiation is referred to as thermal radiation. Since visualization is easier than other sensors.



- IR does not need as much serious preprocessing as GPR. However, the performance of IR relies highly on the environment at the moment of measurement.
- IR can work in either way, actively or passively. It can work by accepting only the natural radiation from the object, or it can provide an extra heat source and receive the artificial radiation created by that heat source .
- The general concept of using infrared thermography for mine detection is based on the fact that mines may have different thermal properties from the surrounding material.



## IR Theory of Operation

- The sensor (detector) is a transducer that converts the energy of EM radiation into an electrical signal.
- There are two kinds of IR detectors, the photon detector and the thermal detector. Where the basic distinction between the two detectors exists in the manner of how they respond to radiation.
- The photon detector or the photon counter essentially measures the rate at which quanta are absorbed.
- whereas the thermal detector measures the rate at which the energy is absorbed.

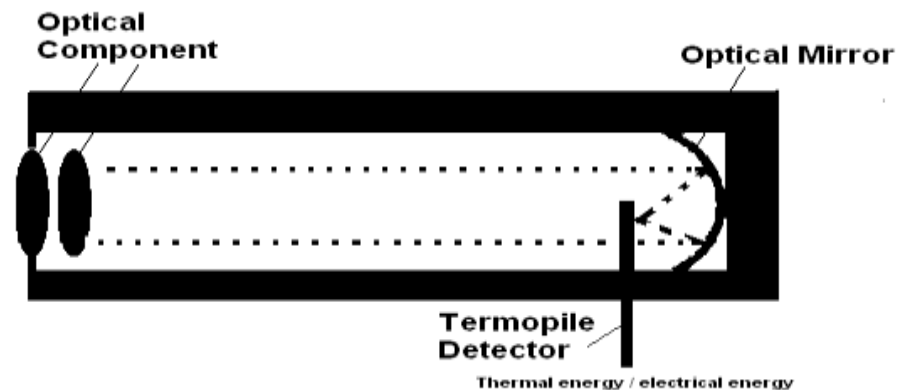

Therefore, the photon detector is the selective detector of infrared, responding only to those photons of sufficiently short wavelengths. Their response at any wavelength is proportional to the rate at which photons of that wavelength are absorbed.

Thermal detectors respond to only the intensity of absorbed radiant power disregarding the spectral content. Thus, they respond equally well to the radiant energy of all wavelengths.



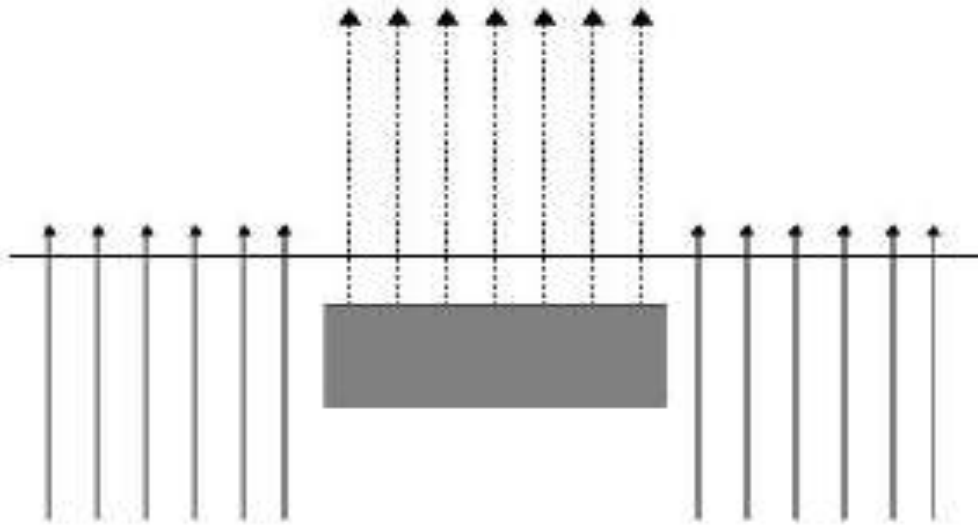

**Volume effect**

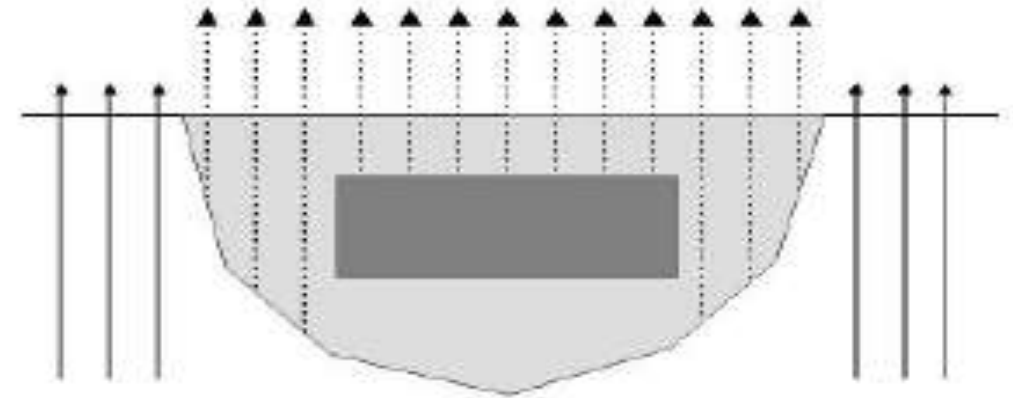

**Surface effect**

the fact that mines may have different thermal properties from the surrounding material.

If a whole scene is submitted to an energy flux that varies with time, the objects will follow a temperature curve that will not coincide with the soil. When this contrast is due to the alteration of the heat flow by the presence of the buried mine, it is called volume effect . When the contrast results from the disturbed soil layer created by the burying operation, it is called surface effect . The surface effect can be detectable for only some time after burial, but during that time the thermal contrast is quite distinctive.



## IR Advantages

- They do not involve physical contact and can be used from a safe standoff distance.
- They are lightweight (1-2 kg) and are effective at scanning wide areas relatively quickly thermal IR sensor typically has a high contrast. This high contrast often exists even when the mine is painted to camouflage its presence.
- IR does not need as much serious preprocessing as GPR. However, the performance of IR relies highly on the environment at the moment of measurement.
- IR can work in either way, actively or passively. It can work by accepting only the natural radiation from the object, or it can provide an extra heat source and receive the artificial radiation created by that heat source.





## The Ultra Sound Sensor.

### Introduction

The frequency range of sound in which average people can hear, is between 20 and 20,000 Hz. Ultra sound waves are the sound waves in the frequency band above this audible range.

### Theory of Operation

The principle of US is very similar to GPR except for the signal. Both sensors emit an active signal and collect reflections from the surroundings.

The sound propagates as a mechanical disturbance of molecules in the form of waves, while GPR signals make no physical disturbance in the medium.

When a sound wave propagates through a medium, the wave consists of the molecules of the medium oscillating around their equilibrium position, but there is no propagation of material just a transmission of disturbance and propagation of only the sound energy.



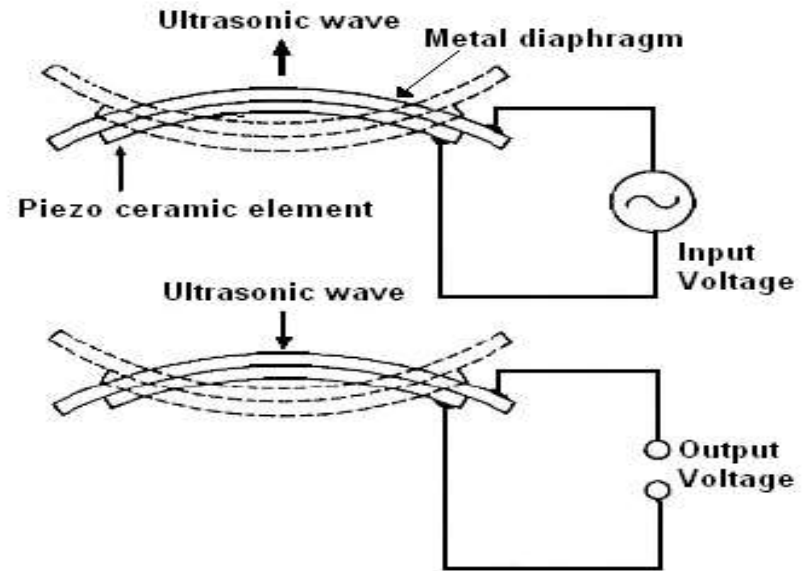

The speed of sound is dependant on the physical properties of its medium, density and elasticity.

The basic definition of the speed of sound is

$$c = f \cdot \lambda [m / sec]$$

Where,

$c$  = the speed,

$\lambda$  = the wavelength,

$f$  = the frequency



factors affecting the US wave behavior:

- The speed of the wave
- The density of the media.

In mine detection, the frequency of US decides the penetration depth as it does for GPR. The lower frequency wave tends to penetrate better than the high frequency.

The US wave propagates well in humid or underwater conditions, but greatly attenuates in the air, while the EM wave of GPR behaves oppositely in the same conditions. Therefore, US is very good and almost the only sensor used for underwater mine detection.

### Some examples of the speed of sound in different materials

Material	Speed of Sound [m/s]
Steel	5000
Lead	1300
Water	1460
Soft tissues	1500



## Types of sensors in the market



Depends on the imaging system of direct three-dimensional realistic, which relies on sending electromagnetic waves in the soil and pick up any object strange in the soil. Example: (metal - caves - spaces ).  
The receiver in the device converts all signals back from the transmitter to processed pictures directly to embody the objects under the ground.



- The radar imaging system detects all metals with the distinction between them accurately with surrounding form and size.
- On the computer screen computerized system installed on the device shows all data and coordinates through it.





The device sends a strong electromagnetic currents to penetrate the soil which covers a circular area of 4 m<sup>2</sup>, the sensor is provided with screen to displat the objects detected.



**MINESWEEPERS**  
TOWARDS A LANDMINE-FREE WORLD

Buried Mine Detection



## AN/PSS-14

The AN/PSS-14 is Handheld Standoff Mine Detection System by combining ground penetrating radar (GPR) and highly sensitive metal detector (MD) technology using advanced data fusion algorithms.

This unique combination enables the system to reliably and consistently detect anti-personnel (AP) and anti-tank (AT) mines and to reject the detection of metallic clutter, increasing operator confidence and efficiency.

An advanced metal detector coil encompasses the diameter of the sensor head. Passing current through the MD coil creates an electromagnetic field that induces an electrical current in any metal object that might be buried in the soil. The sensor head detects this secondary electromagnetic field and responds with an alarm, alerting the soldier to the possible presence of a mine.



## Minelab X-Terra 705 Metal Detector

Single frequency detectors allowing you to change the frequency simply by changing coils. Compatible with low, mid and high frequency waterproof coils.



Automatic/Manual Ground Balancing, Tracking and now with Tracking Ground Balance Offset adjustment. This creates a performance advantage in certain areas such as wet/dry sand transition and hot rock locations, by setting the balance slightly positive or negative.

Preset detecting patterns, that can also be customized plus All-Metal mode.

Adjustable Iron Mask – designed for Prospecting Mode. This feature allows you to find desirable targets lying close to ferrous metals.





***Thank you*** 

[WWW.LANDMINEFREE.ORG](http://WWW.LANDMINEFREE.ORG)